

Rev. NO.	Change Order	Date	Note	Prepared by	Approved by
04	---	04.02.19	Adding static & dynamic loading	Shariati	Gharasl

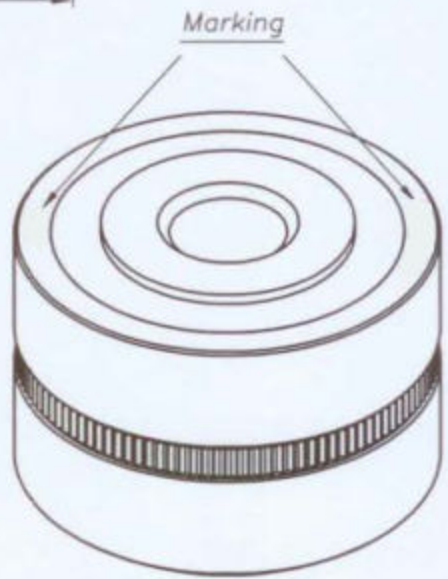
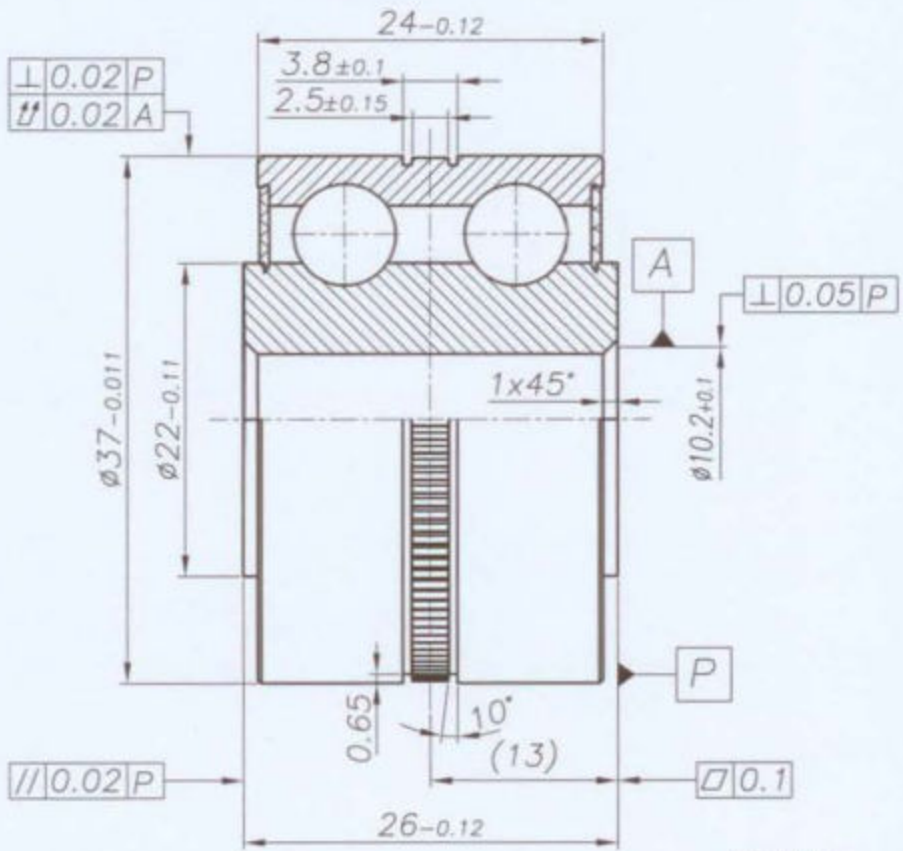

- Basic load rating :  $C_r=15300N$   
 $C_{or}=8700N$
- Marking : As drawing
- Noise  $\leq 40$  dB
- Working temperature  $-40^\circ C$  to  $+120^\circ C$
- Working speed 2000-8000 RPM
- Grease weight 0.9-1.3gr
- Radial clearance 0.02-0.04mm
- knurled stripe on outer ring surface:  
knurled diameter  $36.7_{\pm 0.15}$   
Number of teeth 94  
Tooth depth 0.5
- All specification are obtained from bearing serie No.0 DIN628  
except are shown in drawing

$\sqrt{Ra0.8}$